

AMiS-30EP Pole Cart



Features

- IPX1-rated protection from water ingress
- Built-in cable management minimizes trip hazard
- Tilt-resistant base with sturdy center pole
- Multi-purpose utility basket for storage
- 4" casters and round tread wheels ensure easy portability
- Can be rapidly assembled

Specifications

Category	Attribute	AMiS-30EP
Base Cart	Footprint	20" x 19" (512 x 482 mm)
	Height	1400 mm
	weight	15kg/33 lb
	Casters	125 mm x 125 mm (Anti-Static Medical casters, two locking, two non-locking)
	Height Adjustment Range	Fix
	Display Holder	Standard VESA Mount (VESA 75/75; VESA 100/100); Weight capacity: max. 27lb/ 12kg
	Basket	L280 x W140 x H160mm
	Handle space	200 x 102mm

AMIS-30EP Pole Cart

Dimensions

Unit: mm

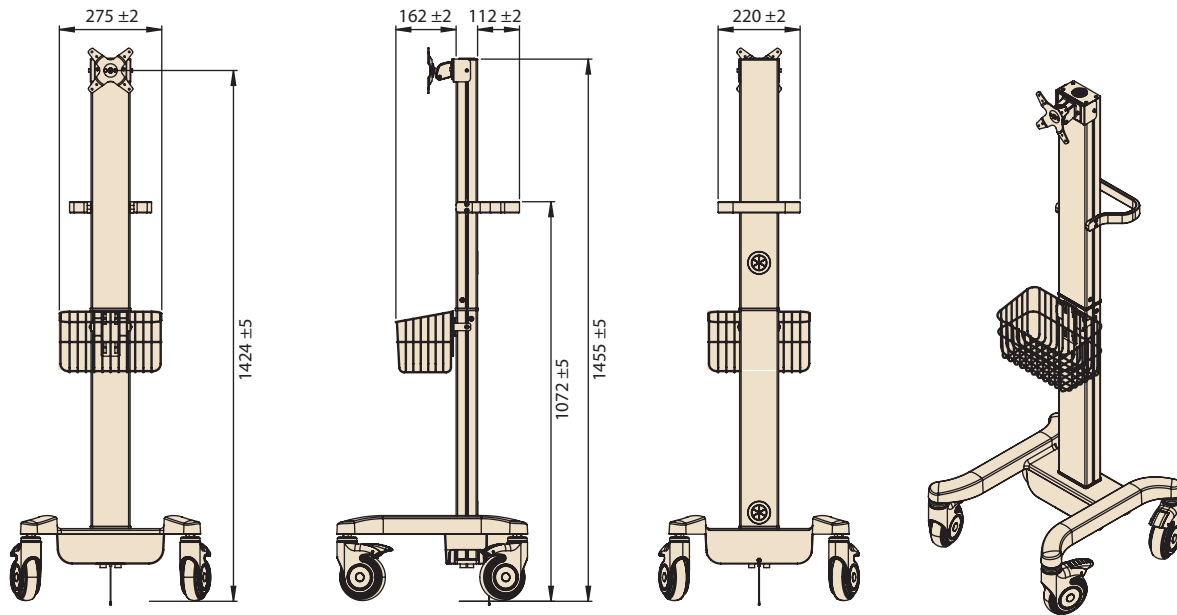

Order Information

Part Number	Product Description
AMIS-30E-1P1-Z3NE	With basket and handle (without monitor)
AMIS-30E-KB-01-AE	Keyboard tray w/ individual packing
AMIS-30E-MB-00-AE	Mouse holder and Barcode Scanner holder w/ individual packing
AMIS-50-TC-30-AE	Trash Can w/ individual packing

