

# AMiS-30EG Gas Spring Cart



## Features

- Nurse-friendly weight reduces nursing fatigue
- Works with a broad range of accessories for specific workflows
- Simple height adjustment for all clinicians to work comfortably and effectively

## Specifications

Category	Category Attribute	AMiS-30EG
Base Cart	Surface	490 x 470 mm/19.2 x 18.5 in Extra loading capacity: Up to 15 kg/33 lb
	Footprint	512 x 482 mm/20 x 19 in
	Casters	125 x 125 mm (anti-static medical casters, two locking, two non-locking)
	Height Adjustment	Gas Spring lift Work Surface Height Range 868 ~ 1168 mm/34 ~ 46 in VESA Center Height Range 1178 ~ 1478 mm/46 ~ 58 in Stroke: 300 mm/11.81 in
	Display Holder	Standard VESA Mount (VESA 75/75; VESA 100/100); Weight capacity: max. 12 kg/27 lb
	Weight	27 kg/60 lb

# AMIS-30EG Gas Spring Cart

## Dimensions

Unit: mm

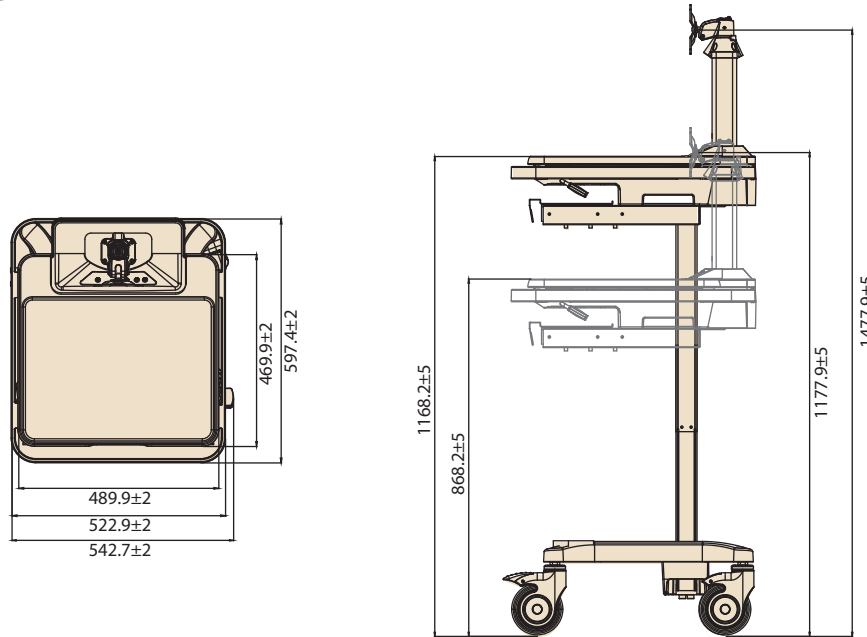

## Ordering Information

Item	Part Number	Spec
AMIS-30EG	AMIS-30E-1G2Z3NE	Gas spring, w/o battery

## Optional

Item	Part Number	Spec
Mouse Holder	AMIS-50-MH-00-AE	Mouse holder w/ individual packing
Barcode Scanner Holder	AMIS-30E-BS-00-AE	Barcode Scanner Holder w/ individual packing
Basket	AMIS-60-BK-00-AE	Basket (L28cmxW14cmxH16cm) & Mount Kit w/ individual packing
Trash Can	AMIS-50-TC-30-AE	Binocular Nursing Trash Can w/ individual packing