

26" HD LED Medical Display

FS-P2603D



The superb picture quality and wide viewing angles found in FS-P2603D offer the optimal visualization requirements demanded in today's OR. Medical professionals can view crystal clear images from a variety of locations in the room.



Ultimate Compatibility

FS-P2603D accepts a large selection of video signal types, analog or digital. It also features rapid signal detection of imaging sources found in the OR. This means that FS-P2603D is compatible with nearly every surgical video integration application, old or new. It offers seamless deployment in surgical suites where many different video signals are present.

Signal inputs: DVI-D (2), 3G-SDI (2), SOG (2), VGA, C-Video, S-Video, Component Video.

Signal outputs: DVI-D (2), 3G-SDI (2), SOG (2), C-Video, S-Video, Component Video.

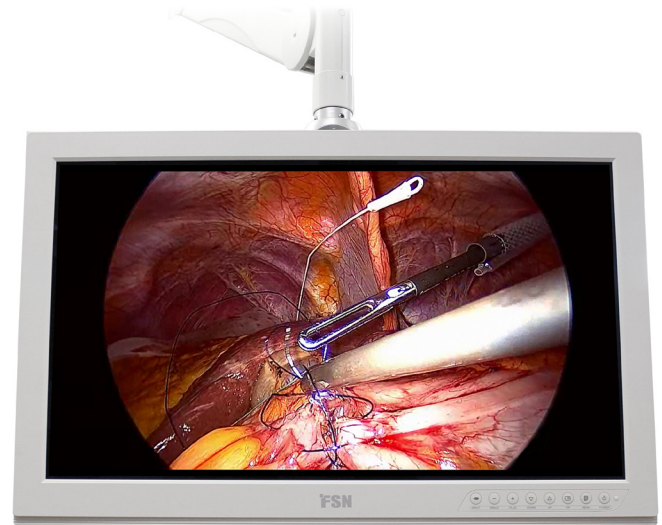

Attention to Detail

FS-P2603D has the latest advanced features built in, including precise image controls and on-board DC out power for smaller component needs. Images can be zoomed, panned left or right, or freeze-frame. Two separate video signals can be shown as picture-in-picture or side-by-side.

FS-P2603D is constructed to medical-grade standards, and is ready out of the box for near-patient use in the sterile field. It can be easily mounted on spring arms, surgical booms, or mobile carts.

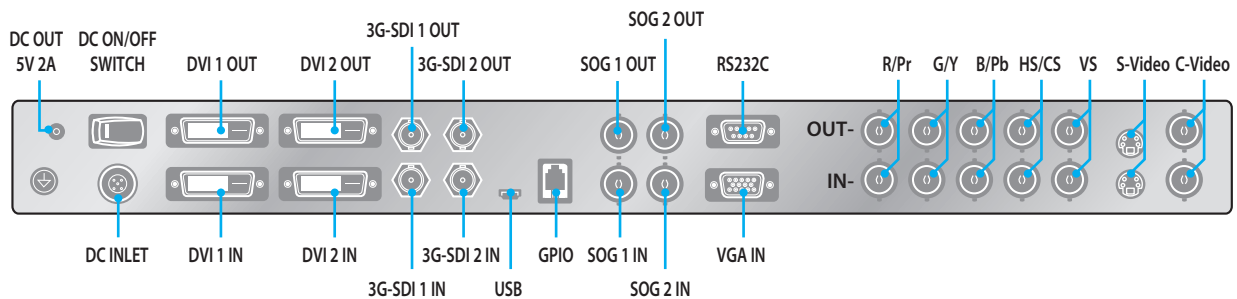

www.fsnmed.com

Foreseeson Custom Displays, Inc.
2210 E. Winston Road
Anaheim, CA 92806 USA
Tel: 714-300-0540
Fax: 714-300-0546

San Jose, CA Tel: 714-507-3851
Fort Lee, NJ Tel: 714-507-3852

Foreseeson Korea
404B, PangyoInnovalley B
253 Pangyo-ro
Bundang-gu Seongnam-si
Gyeonggi-do, Korea 463-400
Tel: +82-31-8018-0780
Fax: +82-31-8018-0786

Foreseeson GmbH
Industriestrasse 38a
63150 Heusenstamm, Germany
Tel: +49 6104 64398 0
Fax: +49 6104 64398 11

Foreseeson UK Ltd.
Unit 71 Barwell Business Park
Leatherhead Road
Cheshington, Surrey KT9 2NY
Tel: +44 (0) 208 546 1047

Foreseeson (Shanghai)
Medical Equipment Co., Ltd.
Room 307, 3F
No. 56, 461 Hongcao Road
Caohejing Development District
Xuhui, Shanghai 200233
Tel: 86-21-6113-4188

26" HD LED Medical Display

FS-P2603D



Specifications

General Features

Item	Description
Panel	26 inch TFT LCD (LED)
Resolution	1920 x 1080 pixel
Aspect Ratio	16 : 9
Active Area	576.0(H)mm x 324.0(V)mm
Pixel Pitch (mm)	0.30 x 0.30
Response Time	10 ms (typ. rise time)
Number of Colors	1.07 Billion
Brightness (typical)	450 cd/m ²
Contrast Ratio (typical)	1400 : 1
Surface Treatment	Anti-glare
Viewing Angle (CR>10)	R/L 178°, U/D 178°
Input Signal	2 x DVI-D
	2 x SD/HD/3G-SDI (BNC)
	2 x SOG
	1 x VGA (D-sub)
	1 x C-Video (BNC)
Output Signal	1 x S-Video (DIN)
	1 x Component (RGBS, YPbPr) (5 x BNC)

Item	Description
Output Signal	2 x DVI-D
	2 x SD/HD/3G-SDI (BNC)
	2 x SOG
	1 x C-Video (BNC)
Power Supply	1 x S-Video (DIN)
	1 x Component (RGBS, YPbPr) (5 x BNC)
Power Supply	AC/DC Adaptor (AC 100~240V, DC 24V 6.25A)
Power Consumption	70W max
Accessories Included	User manual, AC-DC adaptor, AC power cord, DVI-D cable, BNC cable, Screw BH M4 x 14
Unit Dimension	668(W) x 421(H) x 88.8(D) mm 26.3(W) x 16.57(H) x 3.5(D) inch
Package Dimension	755.65(W) x 654.05(H) x 234.95(D) mm 29.75(W) x 25.75(H) x 9.25(D) inch
Weight	8.63 kg, 19.03 lbs. (monitor with cover) 13.2 kg, 29.1 lbs. (shipping package)
Certifications	ANSI/AAMI ES60601-1 (UL60601-1), CAN/CSA C22.2 No. 60601-1, FCC Class B, EN60601-1, EN60601-1-2, CE, MDD(93/42/EEC) Class I Medical Device

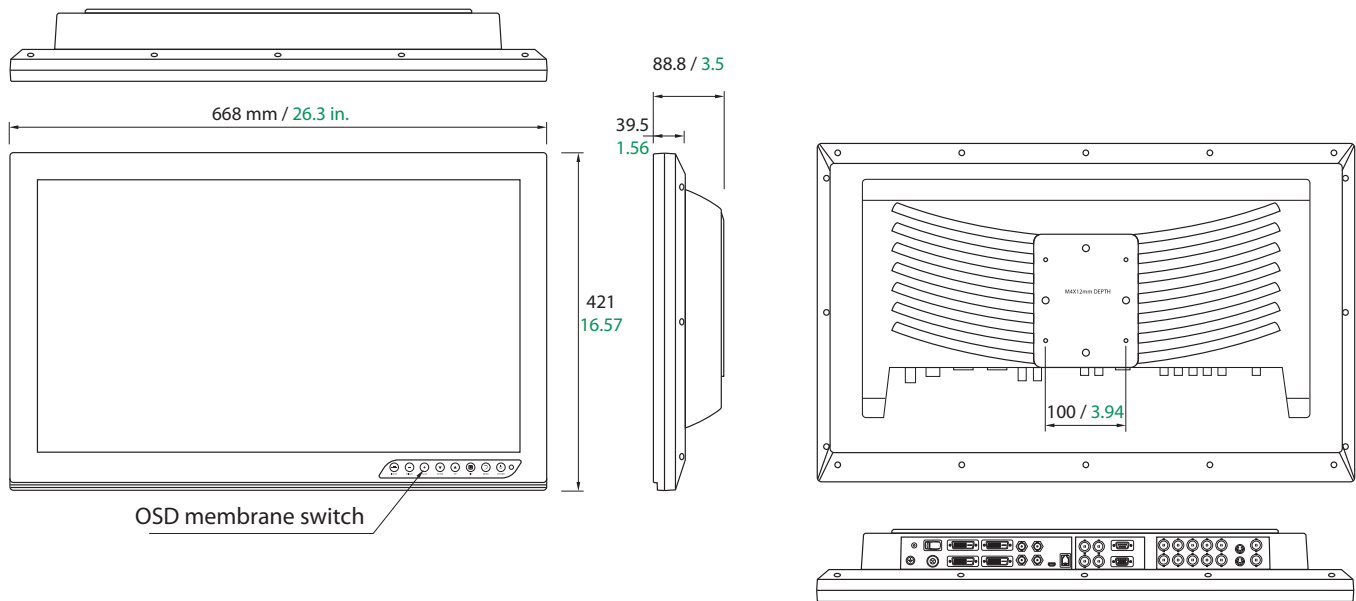

FSN Medical Technologies products meet RoHS2 and Registration, Evaluation, Authorisation and Restriction of Chemicals (REACH) obligations. FSN manages the information flow as required by regulations.

Specifications are subject to change with or without notice. Doc.# FSN1948 Rev. 10/18

www.fsnmed.com

Foreseeson Custom Displays, Inc.
2210 E. Winston Road
Anaheim, CA 92806 USA
Tel: 714-300-0540
Fax: 714-300-0546

San Jose, CA Tel: 714-507-3851
Fort Lee, NJ Tel: 714-507-3852

Foreseeson Korea
404B, PangyoInnovalley B
253 Pangyo-ro
Bundang-gu Seongnam-si
Gyeonggi-do, Korea 463-400
Tel: +82-31-8018-0780
Fax: +82-31-8018-0786

Foreseeson GmbH
Industriestrasse 38a
63150 Heusenstamm, Germany
Tel: +49 6104 64398 0
Fax: +49 6104 64398 11

Foreseeson UK Ltd.
Unit 71 Barwell Business Park
Leatherhead Road
Chessington, Surrey KT9 2NY
Tel: +44 (0) 208 546 1047

Foreseeson (Shanghai)
Medical Equipment Co., Ltd.
Room 307, 3F
No. 56, 461 Hongcao Road
Caohejing Development District
Xuhui, Shanghai 200233
Tel: 86-21-6113-4188