



Features

- 15" Intel® 6th/7th Generation Fanless Stainless Panel PC
- IP66/69K Full Sealed with Anti-Corrosion Enclosure
- Support Intel® vPro technology by CPU
- IP67 M12 Stainless/Metal Connectors
- Special Inspection of 100% Waterproof Guarantee
- CE, FCC, VCCI Class B Certified
- Screen Touch Lock Function

Specification

Product		WTP-9E66-15	
Main System	CPU	Intel® 6 th /7 th generation core i7/i5 processor	
	Graphic	Intel® Graphics HD	
	Memory	Two DDR4 SODIMM socket support dual Channel, up to 32GB	
	OS Support	Optional Windows 7 embedded, Windows 7 pro, Windows 8 embedded, Windows 8 industrial, Windows 10	
Display	Size	15" 4:3	
	Resolution (pixel)	1024 x 768 (XGA)	
	Number of Colors	16.7M colors (RGB 6-bit + Hi FRC)	
	View Angle (H/V)	160(H) / 160(V)	
	Brightness (nit)	450 nits	
	Contrast Ratio	600 : 1 (Typ)	
Touch Panel	Type	Full flat resistive touch panel	Projected Capacitive Touch
	Light Transmission	80 ± 5%	90±3%
	Hardness / Lifetime	4H / 35M times	7H / 100M times
Storage & Expansion	Storage	2.5" SATA HDD or SSD	
	Expansion	Mini PCIe x 1 M.2 Type E x 1	
I/O Ports	USB	1 x M12 8pin for USB 1/2, 1 x M12 8pin for USB 3/4	
	COM	1 X M12 8pin for COM 1/RS-232, 1 X M12 8pin for COM 2/RS-232/422/485	
	LAN	1 x M12 8pin for LAN x 1	
	DC in	1 x M12 5pin DC power connector, DC 9~32V	
	Control Keys	Rear bottom: Power on /off	
Power	Power adapter	AC100~240V/ 47 ~ 63 Hz / DC output 12V, IP67	
	Power consumption	53.8W	
Environmental	Temperature	Operating Temperature 0~40°C/ 0~50°C(change to SSD) Storage Temperature -20~60°C	
	Humidity	Operating & Storage: 10 ~ 90%, non-condensing	
	Water/Dust resistance	IP66 / NEMA4X / IP69K whole set	
Mechanical Characteristics	Housing	Stainless steel (SUS304), chassis type	
	Dimensions (Net: mm)	395 x 309.5 x 58	
	Weights (Net: kg))	8.4kg	
	Mounting	VESA 100*100, side mount (M6*2)	
Certification	CE/ FCC/ VCCI Class B		

WTP-9E66-15

Stainless Steel Panel PC

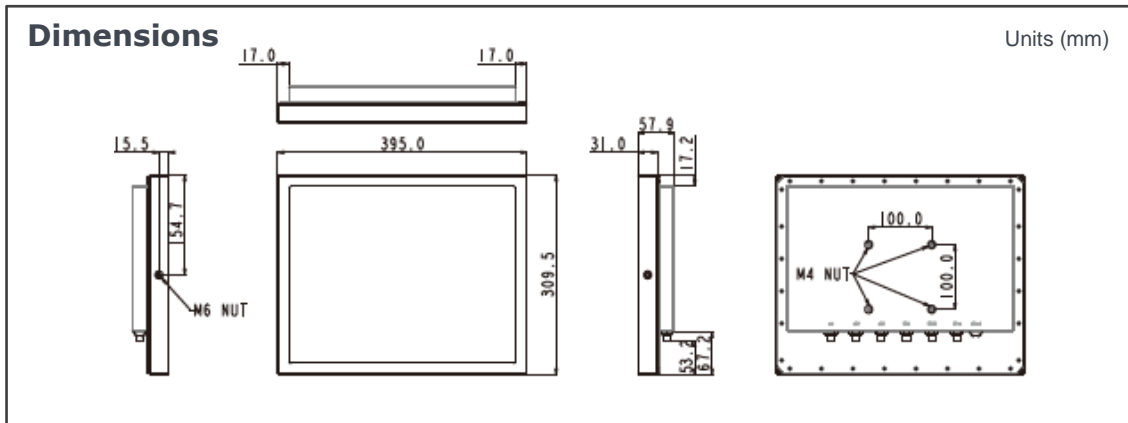

Major Options	
Add On Parts	1. Wireless LAN or Wireless and BT kit (Easy Clean and Robust Antenna or 2 ant), 2. SSD, 3. External LAN x 2, 4. Waterproof USB 3.0, 5. Stainless M12 connector, 6. TPM2.0, 7. IP67, 8. Full Flat PCT Touch Screen IP69K, 9. SUS316 Enclosure
Power Cable	1. Waterproof M12 to 1 x COM cable, 2. Waterproof M12 to 1 x USB cable, 3. Waterproof M12 to 1 x LAN cable
Optional kits	1. Wall mount/ Table mount bracket
Customized	1. Sunlight readable optical bonding, 2. 1000 nit high brightness LCD, 3. LCD Auto dimming, 4. LCD Super dimming (Low brightness), 5. 5W/2WSpeaker, 6. Second HD, 7. COM + power 5V or 12V, 8. Barcode reader

Order Information

Item	Cooling	Description
WTP-9E66-15 (i5)	Fanless	15" Core i5-6200U / DDR4 4G RAM/ 500G HDD/ full flat R-touch
WTP-9E66-15 (i5)	Fanless	15" Core i5-7200U / DDR4 4G RAM/ 128G SSD/ full flat R-touch

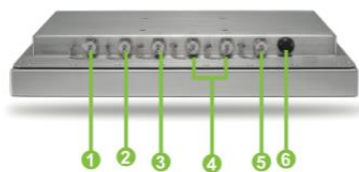

- 1 Giga LAN
- 2 USB 1/2
- 3 USB 3/4
- 4 COM x 2
- 5 DC-in
- 6 Power on/off

