



Features

- Intel® 6th / 7th i7/i5/i3/Celeron Fanless Medical Panel PC
- 19" 1280x1024 LCD panel
- Highest Level EMC 4.0/ Safety 3.1 Certification Ready
- Support Intel® vPro by Optional i7/i5 CPU
- Anti-Bacteria Plastic Housing
- Friendly Design of Front Function Hot-Keys
- Optional Built-In Battery Pack
- Optional PCI-E x 4 Expansion slot
- Support RAID 0.1

Specification

Model	WMP 19C IPOA (STD)	WMP 19C IPOB (ISO)
CPU / Chipset	Intel® 6 th / 7 th generation Core i7/i5/i3/Celeron processor / SoC	
Graphic	Intel® integrated HD Graphics	
RAM	Two 2400 MHz DDR4 SODIMM socket support dual Channel, non-ECC, up to 32GB	
OS Support	Windows 7 embedded, Windows 7 pro, Windows 8 embedded, Windows 8 industrial, Windows 10	
Storage	2.5" SATA HDD drive bay x 1 ,mSATA via mini PCI-E x 1, Optional 2.5" SATA HDD up to 1TB	
Expansion	PCI-E (x4) x1, Mini PCIe x1, M.2 Type E x1 Optional Network Interface: 802.11 ac/a/b/g/n WLAN + Bluetooth module	
Display Size	19" wide TFT-Color LCD	
Display	1280 x 1024 (SXGA), 16.7M colors (MVA, 8 bit), 170(H) / 160(V), 350 nits (Typ. Center point), CR:1000 : 1 (Typ)	
Touch Screen	Full flat projective capacitive touch panel / Light Transmission: 90% ± 3% / Hardness: 7H pencil, pressure 750g/45° / Life: 100M times	
USB	USB3.0 x 4	USB3.0 x 2, USB 2.0 X 2, ISO USB2.0 X 1
COM	RS-232 x 1, RS232/RS422/RS485 X 1	RS-232 x 1, RS232/RS422/RS485 X 1, ISO RS-232 x 1, ISO RS232/RS422/RS485 X 1
LAN	RJ45 X 2	RJ45 x 2, ISO LAN x 1
Audio/ Video	3.5mm phone jack connector * 2 (Line-out, Mic-In) / DP x 2	
Control Hot Key (R to L)	Power Button// Audio adjustment // brightness // LCD on/off // Clean me	
Cooling	Fanless	
Power Input	DC-In x 1, DC 9~32V input	
Power Adapter	AC input 90~264V / 47 ~ 63 Hz / DC output 12V, 100W	
Temperature	Operating Temperature: 0~35°C (chamber) / Storage Temperature: -20~60°C	
Humidity	Operating & Storage:10 ~ 90%, non-condensing	
IP Rating / Housing	IP65 (Front Side) / Front: Full flat design/ Touch (standard)/ Glass(customized); Rear: Plastic White w/Anti-bacteria (MRSA), Housing	
Dimensions (Net)	450.0mm (H) x 420mm (V) x 85.3mm (T)	
Weights (Net)	7.5 kg (w/o power adapter/battery pack)	
Mounting	Optional Stand, VESA 75 / 100	
Certification	cULus/EN/UL/60601-1, 60601-1-2 4th Edition, IEC62133, FCC/CE/VCCI Class B, Energy Star 6.1 Compliance	

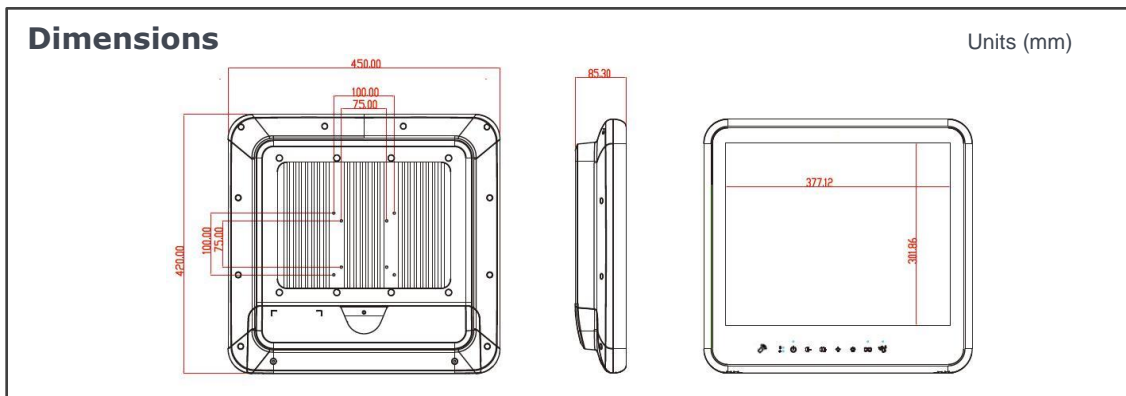

Major Options	
Add On Parts	1. 3.2M Webcam(USB) 2. TPM 2.0 module 3. Wireless or Wireless + BT kit 4. RFID (13.56MHz) 5. AG Film 6. PCI-E [x4] riser card 7. Equipotential Terminal Pin, 8. Full HD Capture Card 9. Battery pack (100W max.) 10. mSATA module 11. 2.5" SSD 12. 4KV Isolation Card x 1 (Isolation COM x 2, Isolation LAN x 1, Isolation USB x 1)
Power Cable	1. Power adapter w/ 2m extension cable 2. Power plug holder 3. Microphone on I/O cover
Optional kits	1. Anti-bacteria Stand 2. VESA Wall Mount
Customized	1. Temper Glass 2. Extra USB x 2 or COM x 2,

Order Information

Item	Configuration
WMP-19C-IP0A-i5	Core i5-6200U 2.3GHz / 4G RAM / 500G HDD / Full flat P.cap touch / STD I.O.
WMP-19C-IP0A-i7	Core i7-6500U 2.5GHz / 4G RAM / 500G HDD / Full flat P.cap touch / STD I.O.
WMP-19C-IP0B-i7	Core i7-6500U 2.5GHz / 4G RAM / 500G HDD / Full flat P.cap touch / ISO I.O.

STD IO Parts

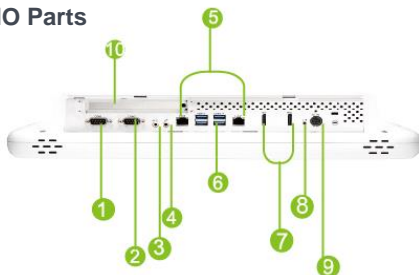

- ① RS232/422/485
- ② RS232
- ③ Line-out
- ④ Microphone-in
- ⑤ LAN x 2
- ⑥ USB 3.0 x 4
- ⑦ DP x 2
- ⑧ Reset
- ⑨ DC-in
- ⑩ PCI-E expansion

